



VEGA SERIES™ | BIFACIAL PV MODULES

INSTALLATION AND MAINTENANCE MANUAL

TABLE OF CONTENTS

1 MANUAL OVERVIEW	02
1.1 DISCLAIMER OF LIABILITY	02
1.2 DECLARATION	02
2 UNPACKING AND STORAGE INFORMATION	02
3 SAFETY PRECAUTIONS INFORMATION	03
4 ENVIRONMENTAL CONDITIONS INFORMATION	04
4.1 ENVIRONMENTAL CONDITIONS	04
4.2 INSTALLATION SITE	04
5 MOUNTING OVERVIEW	05
5.1 MOUNTING	05
5.2 MOUNTING WITH BOLTS	07
5.3 MOUNTING WITH CLAMPS	08
5.4 GROUNDING	11
6 ELECTRICAL CONFIGURATION INFORMATION	12
7 WIRING AND NOTES INFORMATION	13
8 MAINTENANCE INFORMATION	16
9 WARNING	16

1 | MANUAL OVERVIEW

This manual offers general information regarding installation and maintenance of photovoltaic modules manufactured by Boviet Solar, which thereafter will be referred to as “modules.”

These manual instructions should be read and understood before installation, handling, or maintenance. To ensure the correct and safe use of the photovoltaic modules, the installer should be familiar with the mechanical and electrical requirements for photovoltaic systems.

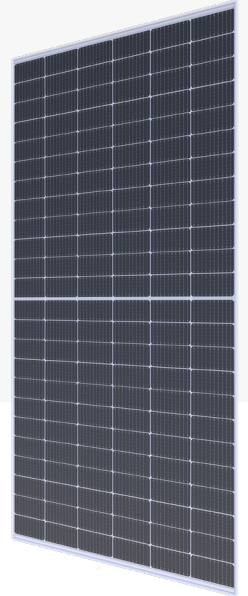

1.1 DISCLAIMER OF LIABILITY

The installation, handling and use of modules are beyond Boviet’s control, and Boviet Solar does not assume responsibility for loss, damage, injury, or expense resulting from the improper installation, handling, use, or maintenance of the module.

Boviet Solar assumes no responsibility for any infringement of patents or other rights of the third parties that may result from use of the module. No license is granted by implication or under any patents or patent rights.

Boviet Solar reserves the right to update this manual, module specifications and/or relevant information without prior notice.

1.2 DECLARATION

The fire rating of the module is valid only when mounted in the manner specified in the mechanical mounting instructions.

The module is considered in compliance with UL 1703/61730 or IEC 61215/61730 only when mounted in the manner specified in the mechanical mounting instructions below.

A module with exposed conductive parts is considered to be in compliance with UL 1703/61730 or IEC 61215/61730 only when it is electrically in accordance with the instructions presented below and the National Electrical Code.

Any module without a frame (laminator) should not be considered to comply with the requirements of UL 1703 or IEC 61215/61730 unless the module is mounted with hardware that has been tested and evaluated with the module under this standard or by a field engineer certifying that the installed module complies with the requirements of UL 1703/61730 or IEC 61215/61730.

2 | UNPACKING AND STORAGE INFORMATION

1. At the time of receipt, verify that the product delivered is the same product ordered. The product name, sub name, and serial number of each module are clearly marked on the outside of each packing box.
2. Store packing boxes in a dry and ventilated room.

3. Leave the product in its original packing box until it is ready for installation.
4. If pallets are stored outside temporarily, a protective covering over the pallet should be placed to protect products from direct weathering. Pallets should not be stacked more than one pallet high.
5. At the installation site, keep modules and electrical contacts clean and dry before installation.
6. Do not stack more than the maximum amount of allowable pallets on top of each other. Do not exceed two layers of pallets high.
7. Do not place modules directly on top of each other.
8. Do not place excessive loads on the module or twist the module frame.
9. Do not stand, step, walk and/or jump on the module.
10. Do not carry a module by its wires or junction box but by its frame with both hands by two or more persons.
11. Do not mark the module with a sharp instrument.

3 | SAFETY INFORMATION

The instructions in this safety manual are intended to prevent danger, damage, and failure.

DO NOT touch electrically active parts of the panel, such as the output wiring, without the adequate safety protection. Bare contact may cause an arc or shock that can lead to injury or even death. Do not use a module that is broken, torn, or damaged. Non-conformity may cause damage, failure, and/or serious bodily injury.

1. Before installing a system, contact the appropriate authorities for site installation, inspection permission/s and requirement/s.
2. Operators shall foresee the risk of injury during the processes of installation, troubleshooting and maintenance of the modules. Therefore, only authorized, and trained personnel should have access to, and perform work on the modules or system.
3. Ensure that modules meet the technical requirements of the system as a whole.
4. When connecting the modules, remove all metallic jewelry, use properly insulated tools, and wear appropriate personal protective equipment to reduce the risk of electrical injury.
5. Do not disassemble the modules or remove any part of the module.
6. Do not stand, step on, damage, or scratch surfaces of the module.

7. Do not install or handle wet modules.
8. Do not touch the exposed cables or connectors.
9. Do not artificially concentrate sunlight on the solar modules.

4 | ENVIRONMENTAL CONDITIONS INFORMATION

4.1. ENVIRONMENTAL CONDITIONS

Only Install the PV modules within the following conditions:

1. Ambient temperature: -40°C to 40°C
2. Operating temperature: -40°C to 85°C
3. Storage temperature: -30°C to 50°C
4. Humidity: <85RH%
5. Keep modules away from inflammable gas, hazardous chemicals, or fire sources.

4.2. SITE INSTALLATION

1. To ensure the modules receive the most sunlight exposure, position the modules in a manner to minimize the chances of shading throughout the day by trees, buildings, or any other surrendering objects.
2. Solar modules should normally be mounted facing the equator at an angle to the horizontal plane equivalent to the latitude of the installation for optimum energy generation. The module tilt angle is measured between the solar modules and the horizontal (Figure 1). Any slope less than 5in/ft(127mm/305mm) is required to maintain a fire class rating. The PV module generates maximum output power when it faces the sun directly.
3. Do not install modules in the location where they will be immersed in water or continually exposed to water from a sprinkler, hose, or fountain.
4. Please leave a safe working area between the edge of the roof and the external edge of the solar array when installing modules on a roof.
5. Avoid a mounting method that will block the drainage holes in the module frame.

Figure 1. PV Module Tilt Angle

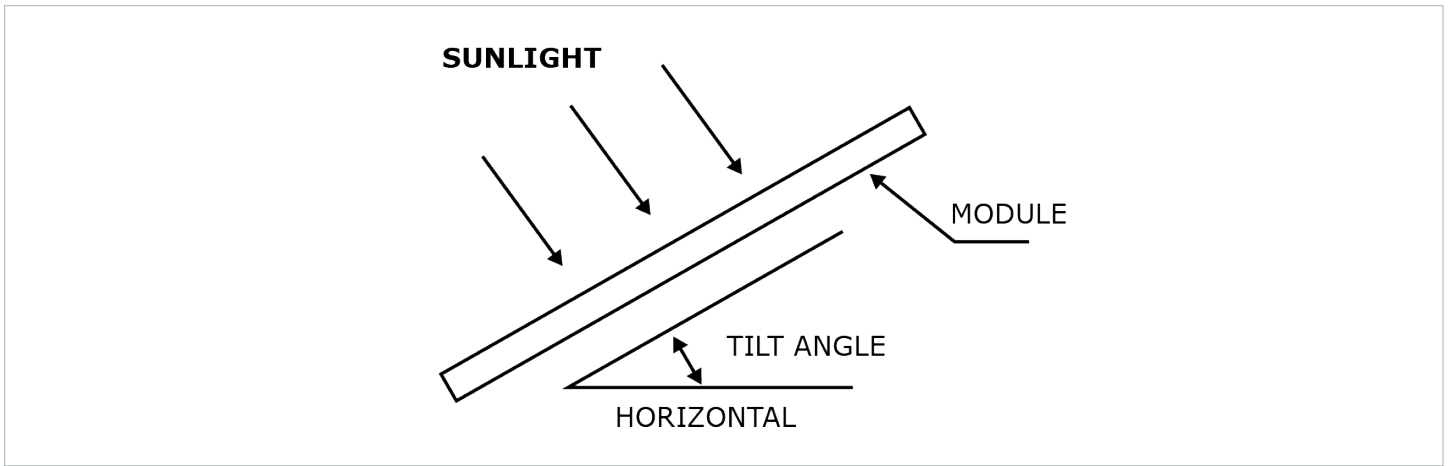

5 | MOUNTING OVERVIEW

5.1 MOUNTING

Solar PV modules usually can usually be mounted by using the following methods: bolts or clamps.

PV modules can be mounted to a substructure with either corrosion-proof M8 (bolts placed through the mounting holes on the module frame) or with specially designed module clamps.

Note: All installation methods herein are only for reference. Boviet Solar will not provide related BOS components. The system installer or trained professional personnel must be responsible for the PV system's design, installation, mechanical load calculation and security of the system.

Regardless of the method, the final installation of the modules should ensure that:

A clearance of at least 115mm (4.5in) is required provided between the module frame and the surface of the wall or roof. The minimum distance between two modules is 10mm(0.4in).

The mounting method should not block the drainage holes.

Panels are not subjected to wind or snow loads exceeding the maximum permissible loads and are not subject to excessive forces due to the thermal expansion of the support structures.

Note: The drainage holes cannot be blocked in any situation during installation or use.

Figure 2: PV Module I Mechanical Drawing

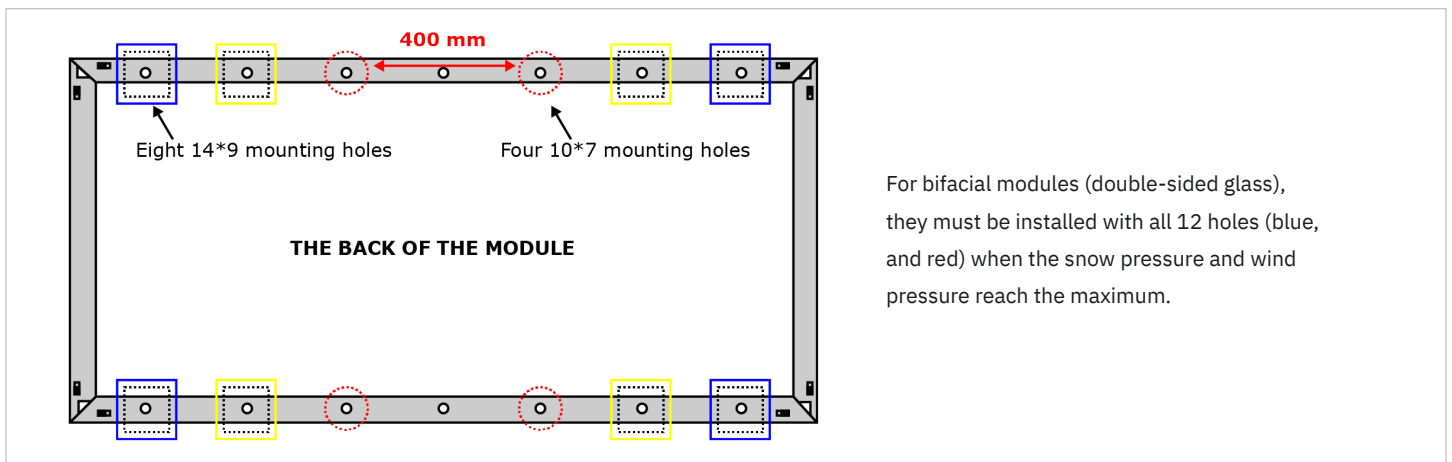

For bifacial modules (double-sided glass), they must be installed with all 12 holes (blue, and red) when the snow pressure and wind pressure reach the maximum.

Figure 3: PV Module I Mechanical Drawing

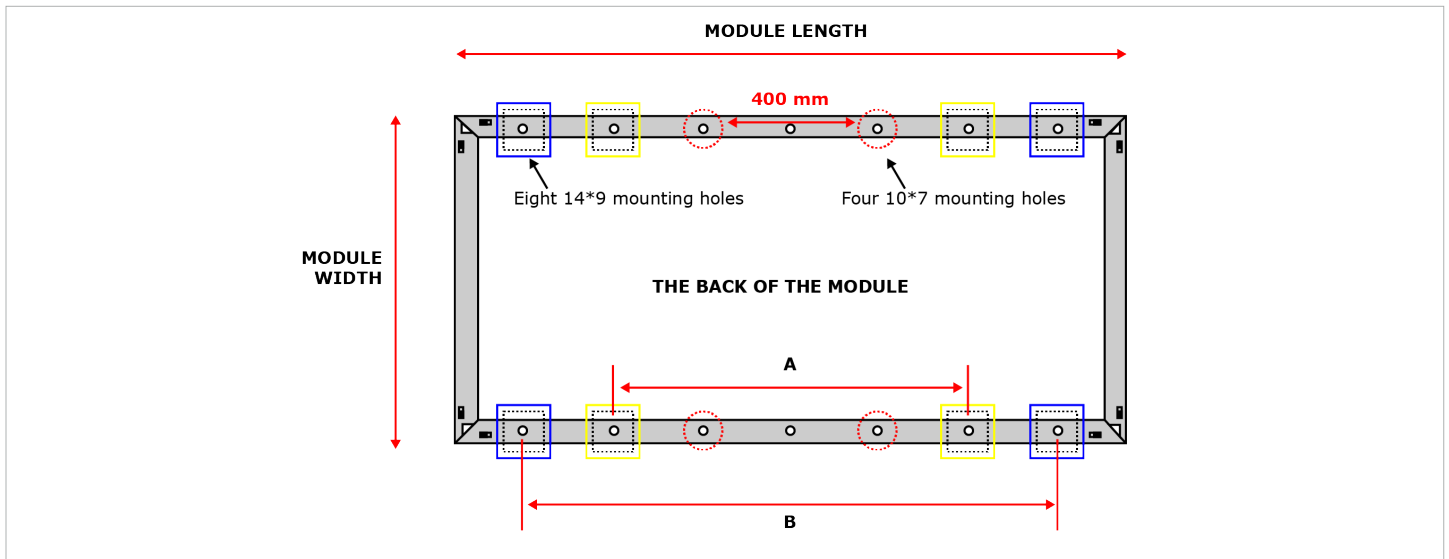

Table 1: PV Module I Installation Hole Spacing

No	PV Cell	PV Module Type	PV Module Size	Installation Hole Spacing
1	182-Half-cut module	BVM7612M-XXX-H-HC-BF-DG (144 cells) BVM7612M-XXX-H-HC-BF (144 cells)	2296*1134*35mm	A:1300 B:1600
2	166-Half-cut module	BVM6612M-XXXS-H-HC-BF-DG (144 cells) BVM6612M-XXXS-H-HC-BF (144 cells)	2135*1046*35mm	A:1080 B:1360
3	166-Half-cut module	BVM6610M-XXXS-H-HC-BF-DG (120 cells) BVM6610M-XXXS-H-HC-BF (120 cells)	1794*1046*35mm	A:1080 B:1260
4	w158-Half-cut module	BVM6612M-XXXL-H-HC-BF-DG (144 cells) BVM6612M-XXXL-H-HC-BF (144 cells)	2052*1002/1004*35mm	A:1080 B:1360
5	158-Half-cut module	BVM6610M-XXXL-H-HC-BF-DG (120 cells) BVM6610M-XXXL-H-HC-BF (120 cells)	1727*1002/1004*35mm	A:960 B:1200
6	158-full cell module	BVM6612M-XXXL-H-BF-DG (144 cells) BVM6612M-XXXL-H-BF (144 cells)	2015*1002/1004*35mm	A:900 B:1300
7	158-full cell module	BVM6610M-XXXL-H-BF-DG (120 cells) BVM6610M-XXXL-H-BF (120 cells)	1693*1002/1004*35mm	A:960 B:1200
8	156-Half-cut module	BVM6612M-XXX-H-HC-BF-DG (144 cells) BVM6612M-XXX-H-HC-BF (144 cells)	2028*992*35mm	A:1080 B:1360
9	156-Half-cut module	BVM6610M-XXX-H-HC-BF-DG (120 cells) BVM6610M-XXX-H-HC-BF (120 cells)	1706*992*35mm	A:960 B:1200
10	156-full cell module	BVM6612M-XXX-H-BF-DG (144 cells) BVM6612M-XXX-H-BF (144 cells)	1991*992*35mm	A:900 B:1300
11	156-full cell module	BVM6610M-XXX-H-BF-DG (120 cells) BVM6610M-XXX-H-BF (120 cells)	1673*992*35mm	A:900 B:1300

When the climate of the project site is normal, we recommend using 4-hole mounting (M8 nut). The yellow 4-hole mounting (M8 nut), or blue 4-hole mounting (M8 nut) can be used.

When the climate of the project site reaches severe conditions (2400Pa wind load and 5400Pa snow load), the blue or yellow 4-hole mounting (M8 nut) need to be used, in addition to the middle red auxiliary mounting hole (M6 nut).

In any case clamps should not contact the glass or deform the assembly frame.

The surface of the clamps touching the frame should be flat and smooth; otherwise, the frame and components may be damaged. For better performance be sure to avoid shading from module clamps.

The drainage holes are not blocked by clamps.

The module frame is not modified under any circumstances as this will not void the warranty.

5.2 MOUNTING WITH BOLTS

There are four 4 (9*14mm) and six (7*10mm size) mounting holes at each panel to mount the modules on a supporting structure. The module frame must be installed on the mounting rail using M8 corrosion-proof screws together with spring washers and flat washers in four (4) symmetrical locations on the module.

The applied torque should be approximately 17-23 N*m. The applied torque value should be big enough to fix the modules securely. For special support systems or special installation requirements, please confirm torque value with the specific support supplier. Please find detailed mounting information in Figure 4.

When using six (6) mounting holes, the middle two (2) mounting holes are the auxiliary mounting holes which use M6 bolt. The applied torque should be approximately 7-11 N*m for these bolts. PV module mounting information when installed with screw fitting method as showed Figure 4.

Figure 3: PV Module I Mechanical Drawing

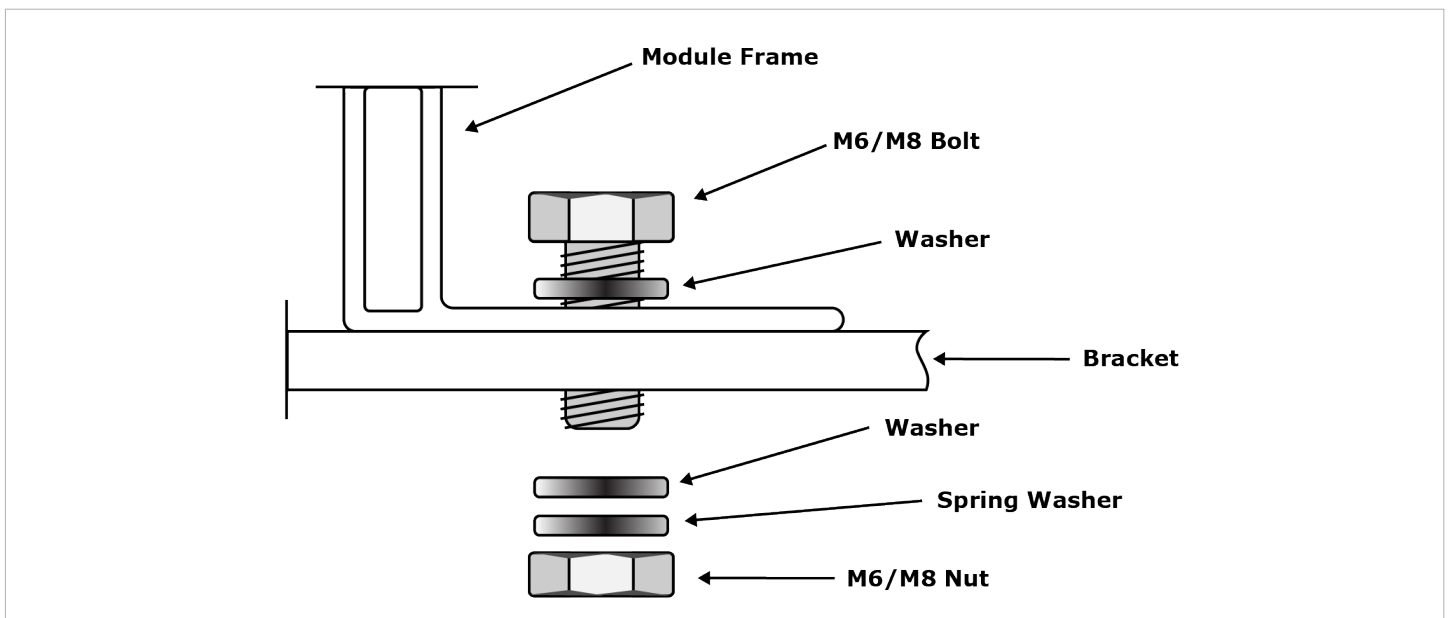

5.3 MOUNTING WITH CLAMPS

Mounting with clamps at the long side of frames

The module frame is not to be modified under any circumstance. When choosing this type of clamp mounting method, please be sure to use at least four (4) clamps on each module, two (2) clamps should be attached on the long sides of the module.

Depending on the local wind and snow loads, if excessive pressure load is expected, additional clamps may be required to ensure that the module can bear the loads. The applied torque should be 18-24 N*m.

Table 2: Fixture Range

No	PV Cell	PV Module Type	PV Module Size	Fixture Range
1	182-Half-cut module	BVM7612M-XXX-H-HC-BF-DG (144 cells) BVM7612M-XXX-H-HC-BF (144 cells)	2296*1134*35mm	J:350 K:500
2	166-Half-cut module	BVM6612M-XXXS-H-HC-BF-DG (144 cells) BVM6612M-XXXS-H-HC-BF (144 cells)	2135*1046*35mm	J:385 K:530
3	166-Half-cut module	BVM6610M-XXXS-H-HC-BF-DG (120 cells) BVM6610M-XXXS-H-HC-BF (120 cells)	1794*1046*35mm	J:270 K:355
4	158-Half-cut module	BVM6610M-XXXL-H-HC-BF-DG (144 cells) BVM6610M-XXXL-H-HC-BF (144 cells)	2052*1002/1004*35mm	J:350 K:490
5	158-Half-cut module	BVM6610M-XXXL-H-HC-BF-DG (120 cells) BVM6610M-XXXL-H-HC-BF (120 cells)	1727*1002/1004*35mm	J:265 K:380
6	158-full cell module	BVM6612M-XXXL-H-BF-DG (144 cells) BVM6612M-XXXL-H-BF (144 cells)	2015*1002/1004*35mm	J:360 K:560
7	158-full cell module	BVM6610M-XXXL-H-BF-DG (120 cells) BVM6610M-XXXL-H-BF (120 cells)	1693*1002/1004*35mm	J:250 K:365

Figure 5: PV Module I J and K represent the range of the fixture, A and B represent the module size.

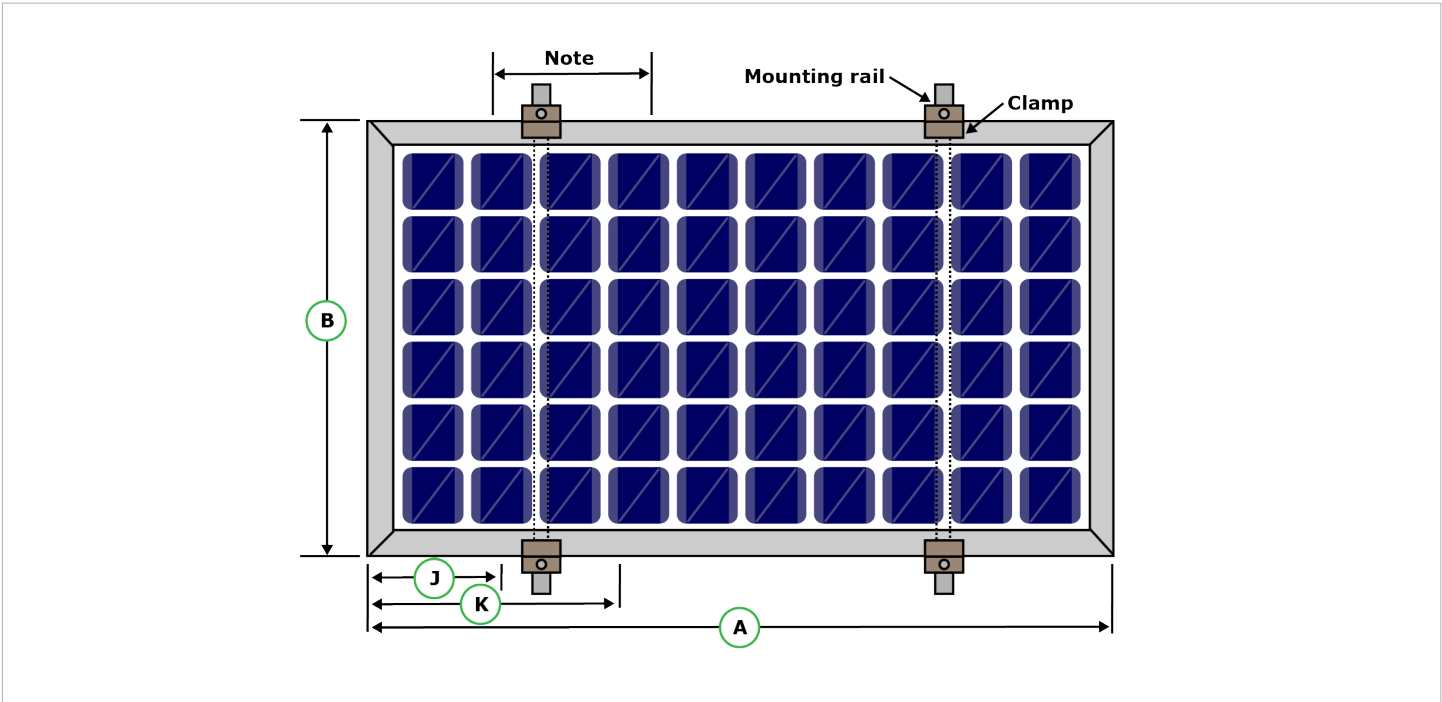

Figure 6: PV Module I PV module installed at long side with clamp fitting method

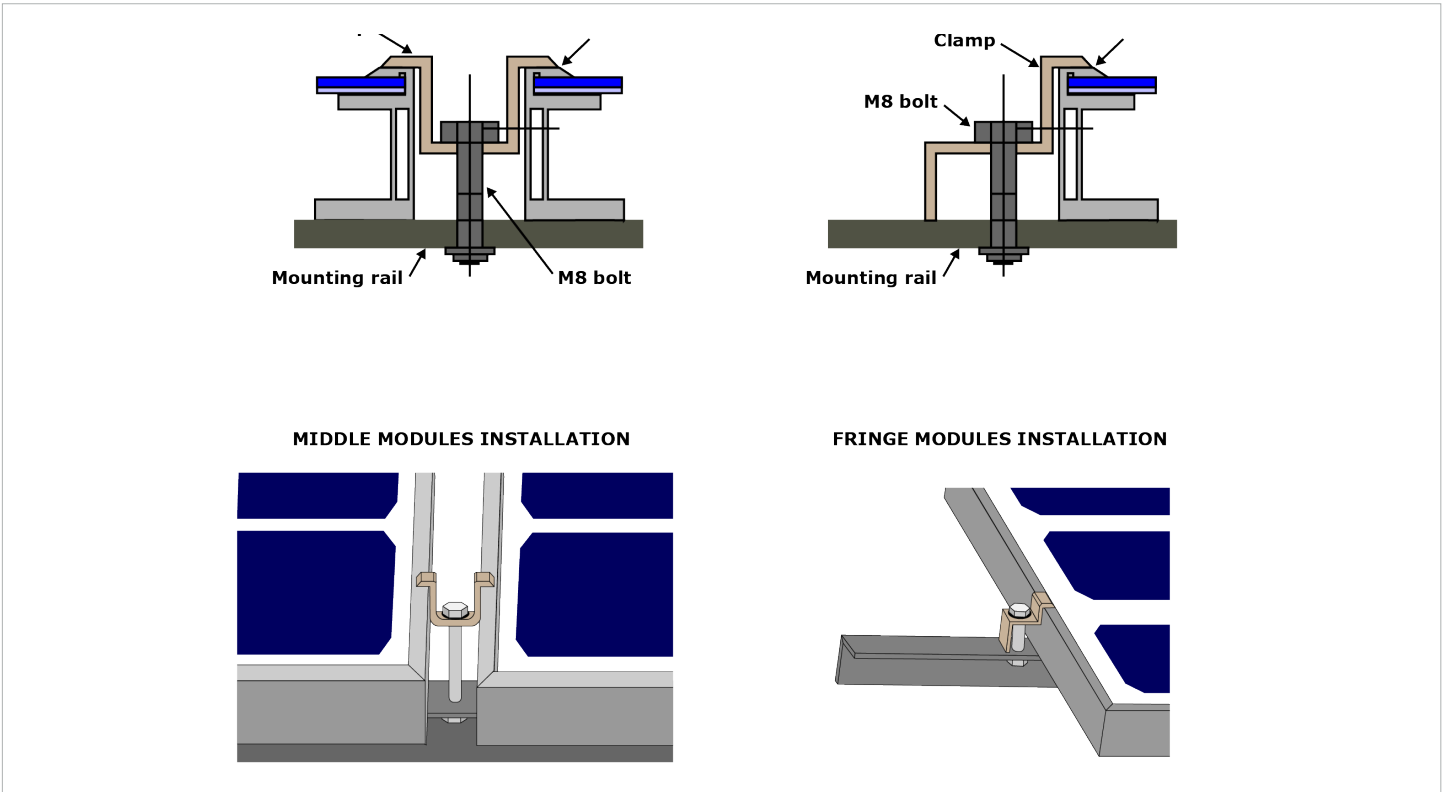

Figure 7: PV Module I Short Side Mounting

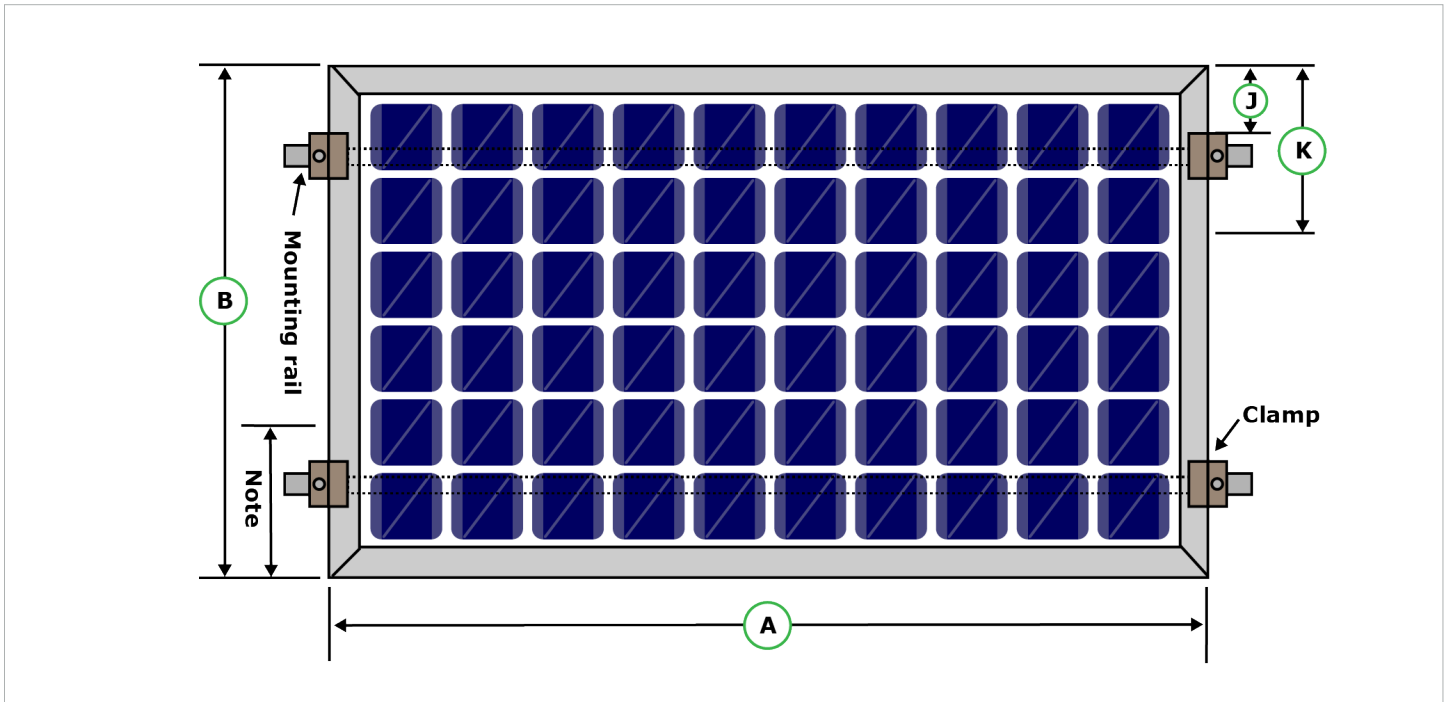

Figure 8: PV Module I PV module installed at short side with clamp fitting method

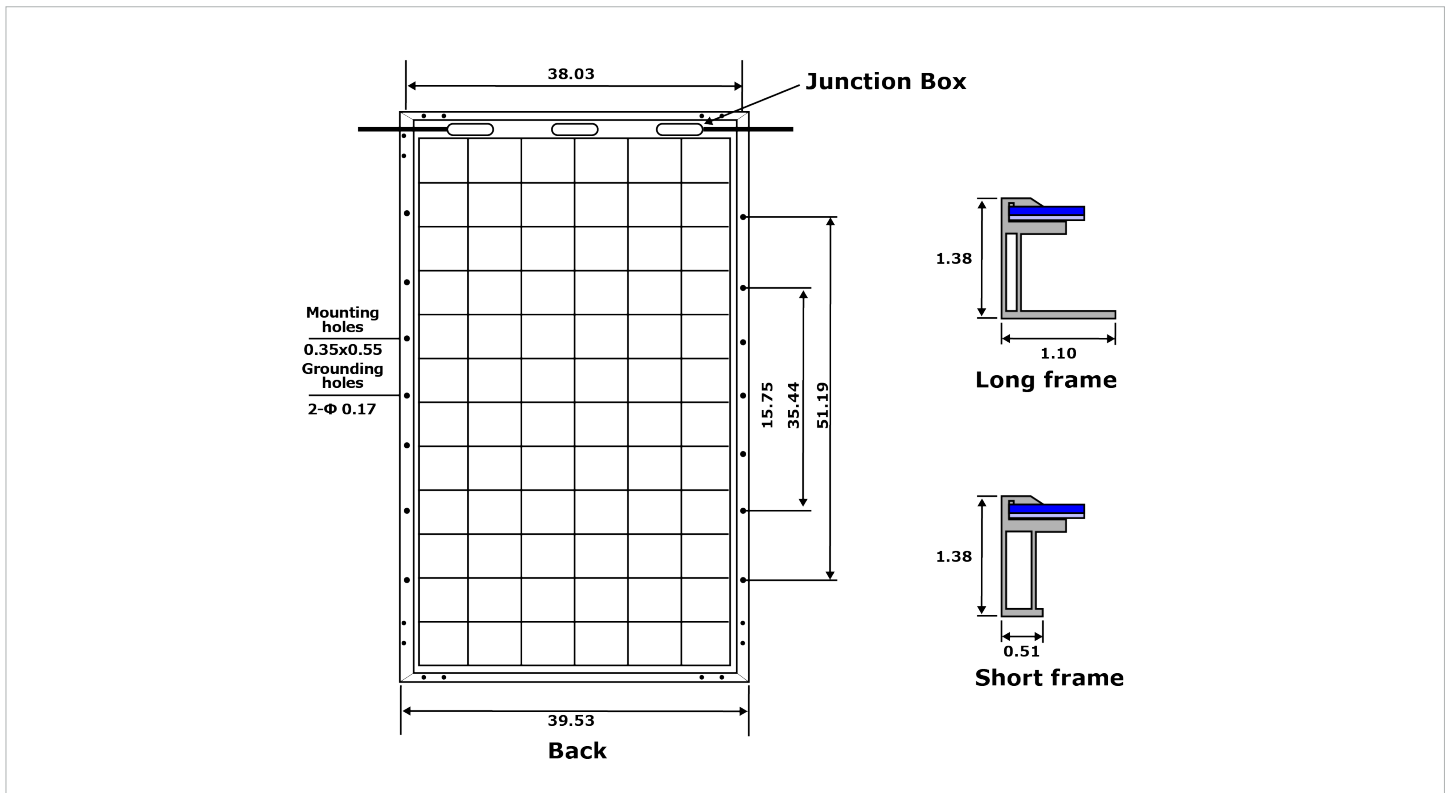

Table 3: Short Side Mounting

No	PV Cell	PV Module Type	PV Module Width(mm)	Fixture Range(mm)
1	182	All	1134	J:80
2	166	All	1046	J:60
3	158.75	All	1002/1004	J:50

5.4 GROUNDING

1. All module frames and mounting racks must be properly grounded in accordance with the National Electrical Code and any local jurisdictions.
2. The modules are required to be grounded, and the module installation needs to comply with all local electrical codes and regulations. Additionally, the grounding connection should be made by a qualified electrician.
3. Proper grounding is achieved by bounding the module frame and all metallic structural components together using a suitable grounding conductor. The grounding conductor or strap may be copper, copper alloy, or another material acceptable for use as an electrical conductor per respective National Electrical Codes. The grounding conductor must make a connection to earth using a suitable earth ground electrode.
4. Where common grounding hardware (nuts, bolts, star washers, split-ring lock washers, flat washers, etc.) is used to attach a grounding/bonding system, the attachment must be made in conformance with the manufacturer's instructions of grounding devices used in the system.
- 6 Common hardware items such as nuts, bolts, star washers, lock washers and the like have not been evaluated for electrical conductivity or for use as grounding devices and should be used only for maintaining mechanical connections and holding electrical grounding devices in the proper position for electrical conductivity. Such devices, when supplied with the module and evaluated through the requirements in IEC and UL standard, may be used for grounding connections in accordance with the instructions provided with the module.
7. Bovie Solar recommends the method below:
 1. A grounding kit with M4 size SS cap bolt, M4 size SS flat washer, M4 size SS cup washer, and M4 size SS nut (with teeth) is to be attach a copper grounding wire to a grounding hole pre-drilled on the frame.
 2. Attach the wire between the flat washer and the cup washer. Ensure the cup washer is between the frame and the wire with concave side up to prevent corrosion due to dissimilar metal. Tighten the bolt securely using the SS nut with teeth (a wrench may be used in this application.) The tighten torque should be 2-3N*m.
8. Alternate grounding options built into the racking system are acceptable as long as they have been UL approved.

Figure 9: PV Module I Schematic drawing for the PV module grounding

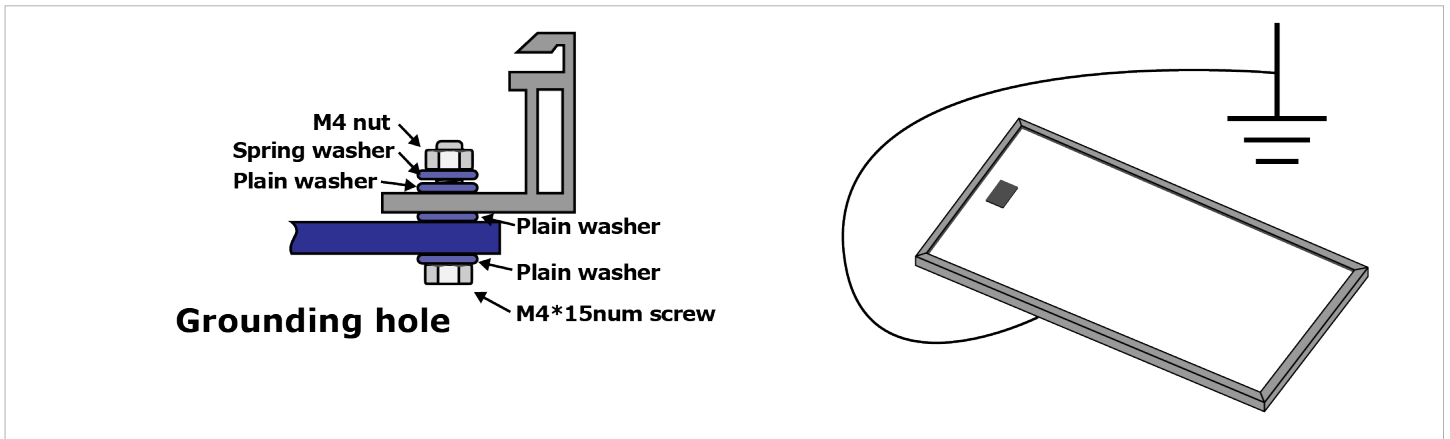

06 | ELECTRICAL CONFIGURATION

PV systems operate automatically and require day-to-day supervision. The solar array generates DC electricity whenever light falls on it. Similarly, the inverter automatically turns ON as soon as there is sufficient solar energy from the array to efficiently convert it into grid quality AC Power.

Boviet Solar produces following models, XXX presents the power range.

Table 4: PV Module Model

No	PV Module Type	PV Module Model
1	Bifacial Double Glass module	BVM7612M-XXX-H-HC-BF-DG
2	Bifacial Transparent module	BVM7612M-XXX-H-HC-BF
3	Monofacial module	BVM7612M-XXX-H-HC
4	Monofacial module	BVM7610M-XXX-H-HC
5	Bifacial Double Glass module	BVM6612M XXXS-H-HC-BF-DG
6	Bifacial Double Glass module	BVM6612M XXXS-H-HC-BF
7	Monofacial module	BVM6612M XXXS-H-HC
8	Bifacial Transparent module	BVM6610M-XXXS-H-HC-BF
9	Monofacial module	BVM6610M-XXXS-H-HC

Table 5: Electrical Data

No	Technical Highlight	Information
1	System voltage (V)	DC1000V/1500V
2	Power Tolerance	0~+5W
3	Insurance Current (A)	15/20 ≥ 40MΩ, M ²
4	Insulation resistance	≥ 40MΩ
5	Application Class	Class A
6	Standard Test Conditions (STC) : AM=1.5, E=1000W/m ² , T=25°C	

The electrical characteristics are within ±10 percent of the indicated values of Isc, Voc and Pmax under Standard Test Conditions (STC) (irradiance of 100mW/cm², AM 1.5 spectrum, and a cell temperature of 25° (77°F)).

Under normal conditions, a photovoltaic module is likely to experience conditions that produce more current and/or voltage than reported at standard test conditions. The requirements of the National Electrical Code (NEC) in Article 690 shall be followed to address these increased outputs. In installations not under the requirements of the NEC, the values of Isc and Voc marked on this module should be multiplied by a factor of 1.25 when determining component voltage ratings, conductor ampacities, overcurrent device ratings, and size of controls connected to the PV output.

07 | WIRING AND NOTES

All wiring should be performed by qualified installers according to the local codes and regulations.



1. Before connecting modules, always ensure that the contacts are corrosion free, clean, and dry.
2. Before connecting modules, verify that the proper electrical values are measured.
3. To minimize the risk of indirect lighting strike and avoid forming closed loops, review that wiring has been properly done before starting. If the measured data of open circuit voltage and short-circuit current differ from the specifications, please check the wiring before proceeding.
4. Products can be irreparably damaged if an array string is connected in reverse polarity to another. Always verify the voltage and polarity of each individual string before making a parallel connection. If strings are connected in reverse polarity and a difference of more than 2V between 10 strings are measured, please check the string wiring before making the parallel connection.

5. The maximum voltage of the system should be less than the maximum certified voltage and less than the maximum input voltage of the inverter and of the other electrical devices installed in the system. To ensure this, the open circuit voltage of the array needs to be calculated at the lowest ambient temperature for the location.
6. Before connecting the components, check the appearance of the material to verify that there is no problem. The connector itself cannot be damaged, have fractures, or have other issues that cause an electrical hazard.
7. Please see the table below for which indicates the connectors to use on the module and the allowable mating connector.

Table 6: PV Module I Connector Information

No	Manufacturer	The Model of the Connector Manufacturer	Allowable Mating Connector	Manufacturer Website
1	Zhe Jiang Jiaming Tianheyuan	PV-JM601	PV-JM601 and PV-JM601A	www.jmthy.com
2	Zhe Jiang Jiaming Tianheyuan	PV-JM601A	PV-JM601 and PV-JM601A	www.jmthy.com
3	Multi-Contact USA	PV-KST4/6II-UR (male) PV-KBT4/6II-UR (female)	PV-KST4/6II-UR (male) PV-KBT4/6II-UR (female)	http://ec.staubli.com/downloads/
4	Multi-Contact USA	PV-KST4-EV02/6II-UR (male) PV-KBT4-EV02/6II-UR (female)	PV-KST4-EV02/6II-UR (male) PV-KBT4-EV02/6II-UR (female)	http://ec.staubli.com/downloads/
5	Amphenol Industrial Operations	UTXCFA4AI	UTXCFA4AI	www.amphenol-Solar.com
6	Amphenol Industrial Operations	Helios H4 Assembled	Helios H4 Assembled	www.amphenol-Solar.com
7	Amphenol Industrial Operations	Helios HH4 Assembled	Helios HH4 Assembled	www.amphenol-Solar.com
8	Zhe Jiang Renhe	05-6-2q	05-6-2q	www.renhesolar.com/cn/index.php

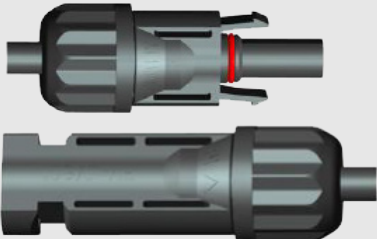
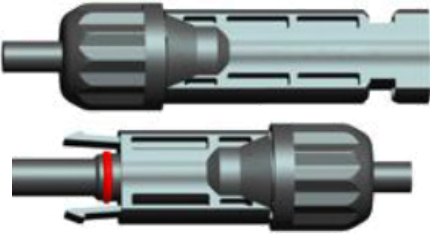
Table 7: PV Module I Connector Images

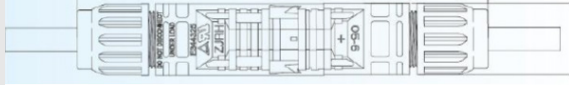
No	Connector Model	Connector Picture	Website
1	PV-JM608		jmthy.com
2	PV-JM601		jmthy.com
3	PV-JM601A		jmthy.com
4	PV-KSTA/611-UR (Male) PV-KBTA/611-UR (Female)		staubli.com/en/connectors/
5	PV-KSTA-EV02/611-UR (Male) PV-KBT4-EV02/611-UR (Female)		staubli.com/en/connectors/
6	05-6-2q		http://www.renhesolar.com/cn/index.php

08 | MAINTENANCE INFORMATION

A well-designed system needs minimal maintenance.

Maintenance should be carried out at least once a year by well-trained personnel.

Check that the mounting hardware is properly tightened. Check if cables, nuts, and bolts are secure and not loose. Tighten any loose components if necessary.

Check ground resistance performance and water resistance of connecting cables, grounding cables, connectors, and any other connections.

Verify that the electrical and mechanical connections are free from corrosion.

Do not touch the live part of the wire, cable, or connector directly, but only with safety equipment (insulating tools and electrical protection) when necessary.

Use an opaque cloth or other opaque materials to cover the front side of the modules during the maintenance. When exposed to sunlight the module may produce high voltage which can cause injury and even death.

In the event that modules need to be cleaned, clean modules with a soft cloth together with a mild detergent and clean water. To avoid severe thermal shocks, which might damage the module, use water at a similar temperature to the modules being cleaned.

09 | WARNING INFORMATION

Contact your installer immediately if you suspect your system is not working properly. For any warranty related concerns contact our Boviet Solar after sales service team at service@boviet.com or your sales contact.

WARNING: The PV system must be shut down first if it needs any electrical maintenance. Improper maintenance may cause burns and/or electrical shock, which can both be lethal.

CONTACT

Address: 2107 N. 1st Street, Suite: 550, San Jose, CA, USA, 95131

Website: bovietsolar.com

Disclaimer: The information included in this document is subject to change without any notice and is provided for informational purposes only. No contractual rights are established or should be inferred because of user's reliance on the information contained in this PV module installation manual. Please contact with Boviet Solar's local offices for more up-to-date product information.